

Compact Split Core

Compact series of split core transformers current transformers offering a cost effective and efficient method by which the current can be measured without the need to break the conductor, thereby reducing installation and commissioning time. Supplied with up to 3 metres of cable for secondary current connections and with integrated shorting links.

Specifications

- Compliant with EN 60044-1 / IEC 61869-1
- Thermal nominal continuous rated current: - 1.2 x I_n
- Thermal nominal short time current: - 60 x I_n, 1 Sec.
- Maximum Operating Voltage: - 0.72 kV
- Rated Frequency: - 50 Hz or 60 Hz
- Insulation Test Voltage: - 3 kV, 1 Min.
- Insulation Class: - E
- Ambient temperature range: -20 to +65
- Storage temperature range: -30 to +70
- Ratios ranging from 60/1 to 500/5
- Suitable only for mounting on insulated primary conductor
- To be used in weather protected & dry location
- Accuracy Class of 1 & 3 *

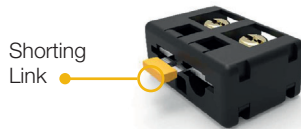

* Used with Provided Cable & tighten with the torque of 2 Nm

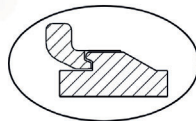

Locking Profile to avoid Accidental Opening



Features

- Hinged Split Core
- Swing open for ease of installation
- Compact size
- Two options for Bus Bar Mounting
- Cable Tie provision for faster installation
- Safety Plug in shorting link
- Available with M4 Size Terminals
- Secondary cable provided with 3 Meter wire for 1A Output
- 1 Meter wire for 5A Output
- Wide range of system current ratings
- Assured Core contact with Latching Type Snap fitment
- Vibration Resistant Design

Compact Split Core

Compact Split Core Current Transformers

(62mm wide x 56.2mm deep x height 110mm. ID 18.5mm)

Cat No.	Ratio	VA at CL3	Cat No.	Ratio	VA at CL3
XCS1-081835B000000	60/1A	0.2VA	XCS1-091835B000000	80/1A	0.2VA
XCS1-021835B000000	75/1A	0.2VA	XCS1-031835B000000	100/1A	0.2VA

Dimensions

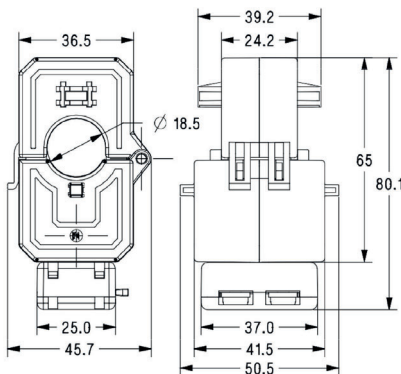

Compact Split Core 36-18



Compact Split Core 50-18

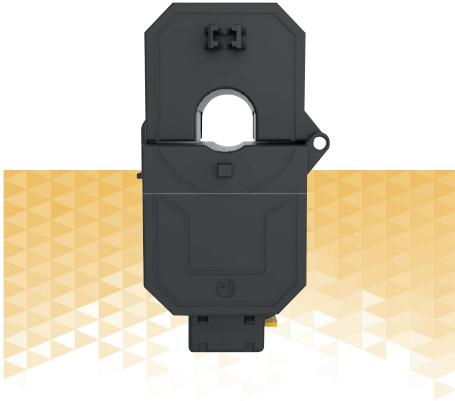

Compact Split Core Current Transformers (62mm wide x 56.2mm deep x height 110mm. ID 18.5mm)

Cat No.	Ratio	VA at CL1	VA at CL3
XCS2-051235B000000	100/1A	-	0.2VA
XCS2-051235B000000	125/1A	-	0.2VA
XCS2-051215B000000	150/1A	0.2VA	-
XCS2-061215B000000	200/1A	0.2VA	-
XCS2-071115B000000	250/1A	1VA	-
XCS2-055215B000000	150/5A	0.2VA	-
XCS2-065215B000000	200/5A	0.2VA	-
XCS2-075115B000000	250/5A	1VA	-

Dimensions

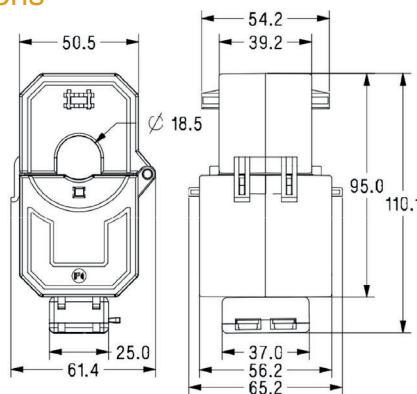

Compact Split Core 50-32

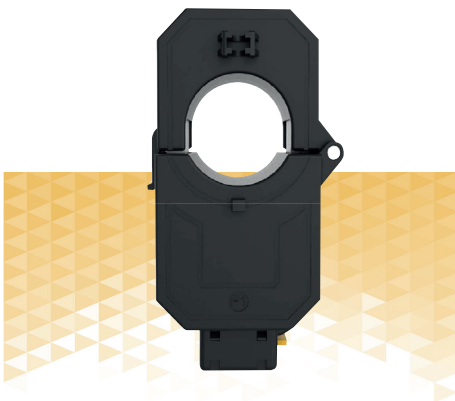

Compact Split Core Current Transformers (62mm wide x 56.2mm deep x height 110mm. ID 32.5mm)

Cat No.	Ratio	VA at CL1	VA at CL3
XCS3-0611035B000000	200/1A	-	0.2VA
XCS3-0711015B000000	250/1A	0.2VA	-
XCS3-0811015B000000	300/1A	0.2VA	-
XCS3-0911015B000000	400/1A	0.2VA	-
XCS3-1011015B000000	500/1A	0.2VA	-
XCS3-0751035B000000	250/5A	0.2VA	0.2VA
XCS3-0851015B000000	300/5A	0.2VA	-
XCS3-0951015B000000	400/5A	0.2VA	-
XCS3-1051015B000000	500/5A	0.2VA	-

Dimensions

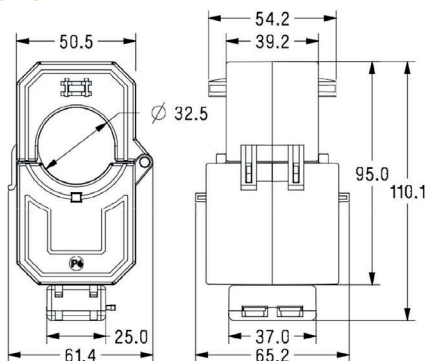

Features given vary from product to product - for more detailed product specific info please visit our website www.sifamtinsley.co.uk