

# N30P DIGITAL PANEL METER

## FEATURES:

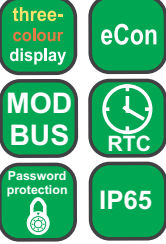

- Measurement of single-phase network parameters: voltage, current, active, reactive and apparent power,  $\cos\phi$ ,  $\tan\phi$ ,  $\phi$ , frequency, active, reactive and apparent energy, 15 minutes' active power, 10 minutes' voltage, 10 seconds' frequency.
- Three-colour display (14 mm high), in three intervals of the measured value.
- Meter programming from the keyboard or through the RS-485 interface by means of the free delivered eCon program.
- Four alarm outputs with signalling by LED diodes, operating in 6 different modes.
- Storage of minimal and maximal values for all measured quantities.
- Conversion of any measured value into a 0/4...20 mA or 0...10 V analog signal.
- Storage of minimal and maximal values for all measured quantities.
- Firmware updating (option).

## INPUTS:



## OUTPUTS:

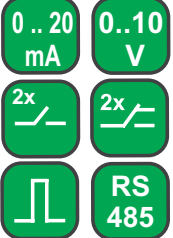

## GALVANIC ISOLATION:

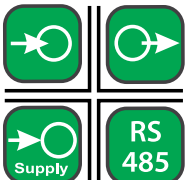

## EXAMPLE OF APPLICATION

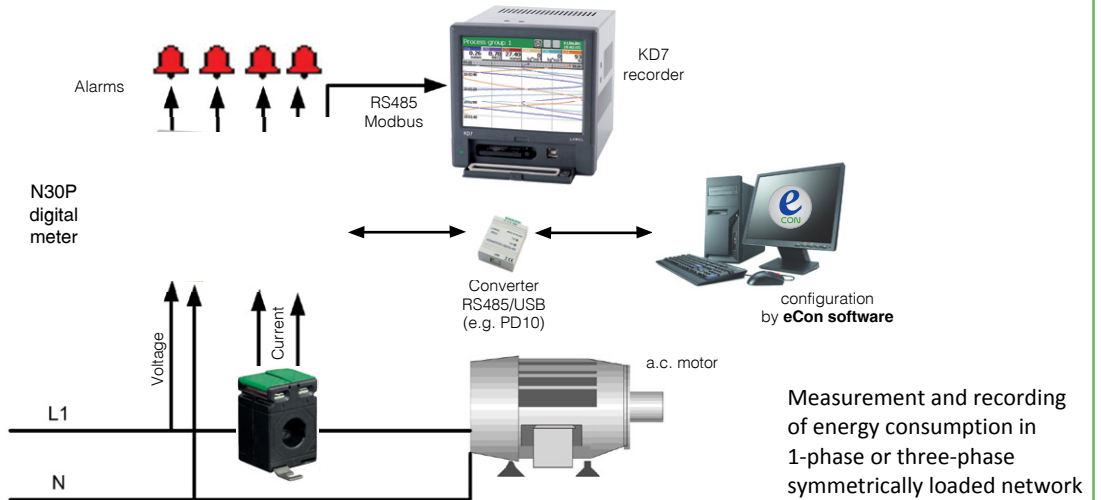

## INPUTS

Input kind	Measuring range	Rated operating conditions	Ratio values
Voltage input	0...100 V or 0...400 V	0.05...1.2 $U_n$	0.1...4000.0
Current input	0...1 A or 0...5 A	0.005...1.2 $I_n$	1...10000

## MEASURING RANGES

Input kind	Indication range	Measuring range	Basic error
Current 1 A/5 A	0.000...60 kA	0.025...6.000 A a.c.	$\pm 0.2\%$
Voltage 100 V/400 V	0.0...1.92 MV	2.0...480 V a.c.	$\pm 0.2\%$
Frequency	45.00...100.00 Hz	45.00...66.00...100.00 Hz	$\pm 0.2\%$
Active power	-19999...99999 MW	-2.88 kW...1.40 W...2.88 kW	$\pm 0.5\%$
Reactive power	-19999...0.00...99999 Mvar	-2.88 kvar...1.40 var...2.88 kvar	$\pm 0.5\%$
Apparent power	0.00...99999 MVA	1.40 VA...2.88 kVA	$\pm 0.5\%$
Cos $\phi$	-1...0...1	-1...0...1	$\pm 0.5\%$
Tangens $\phi$	-1.2...0...1.2	-1.2...0...1.2	$\pm 1\%$
$\phi$	0...359	0...359	$\pm 1\%$
Active energy	0...9 999 999.9 kWh	0...9 999 999.9 kWh	$\pm 0.5\%$
Reactive energy	0...9 999 999.9 kVarh	0...9 999 999.9 kVarh	$\pm 0.5\%$
Current time	0.00...23.59	0.00...23.59	1 sec/ 24 h

## OUTPUTS

Output kind	Properties
Relay output	<ul style="list-style-type: none"> <li>• 2 x relays, voltageless NO contacts, load-carrying capacity 250 V a.c./ 0.5 A a.c.</li> <li>• 2 x relays, voltageless change-over contacts, load-carrying capacity 250 V a.c./ 0.5 A a.c.</li> </ul>
Analog output	<ul style="list-style-type: none"> <li>• current programmable 0/4...20 mA, load resistance <math>\leq 500 \Omega</math></li> <li>• voltage programmable 0...10 V, load resistance <math>\geq 500 \Omega</math></li> <li>• resolution 0.01% of the range</li> </ul>
Energy pulse output	<ul style="list-style-type: none"> <li>• OC type output, passive of class A, acc. to EN 62053-31, supply voltage 18...27 V, current 10...27 mA.</li> <li>• Output pulse constant: 5000 imp./kWh, independently of <math>K_u</math> and <math>K_i</math> settings.</li> </ul>

## DIGITAL INTERFACES

Interface type	Transmission protocol	Mode	Baud rates
RS-485	MODBUS RTU	8N2, 8E1, 8O1, 8N1	4.8; 9.6; 19.2; 38.4 kbit/s

# N30P DIGITAL PANEL METER

## EXTERNAL FEATURES

Readout field	5 digit LED display - indication range -19999..99999 digit height: 14 mm	three-colour display (colour changes depending on displayed value): red, green, orange
Weight	< 0.2 kg	
Overall dimensions	96 × 48 × 93 mm	Panel cut-out: 92 <sup>+0,6</sup> × 45 <sup>+0,6</sup> mm
Protection grade (acc. to EN 60529)	from frontal side: IP65	from rear side: IP 10

## RATED OPERATING CONDITIONS

Supply voltage	85...253 V a.c. (40...400 Hz) or d.c., 20...40 V a.c. (40...400 Hz) or d.c.	Power consumption: - in supply circuit < 6 VA - in voltage/current circuit < 0.05 VA
Temperature	ambient: -25...23...55°C	storage: -30...70°C
Relative humidity	25...95%	condensation inadmissible
Operating position	any	
External magnetic field	0...400 A/m	
Short duration overload (5 s)	voltage input: 2Un (max. 1000 V)	current input: 10 In

## SAFETY AND COMPATIBILITY REQUIREMENTS

Electromagnetic compatibility	Noise immunity	acc. to EN 61000-6-2
	Noise emissions	acc. to EN 61000-6-4
Safety requirements		
Maximal phase-to-earth working voltage	for the supply circuit: 300 V	acc. to EN 61010-1
	for the measuring input 600 V for analog input signals - cat. II (300 V - cat. III)	
	for remaining circuit: 50 V	

## CONNECTION DIAGRAMS

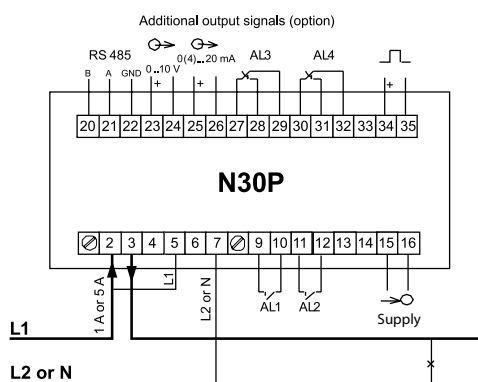

Fig. 1 Electrical connections of the N30P meter for direct measurements.

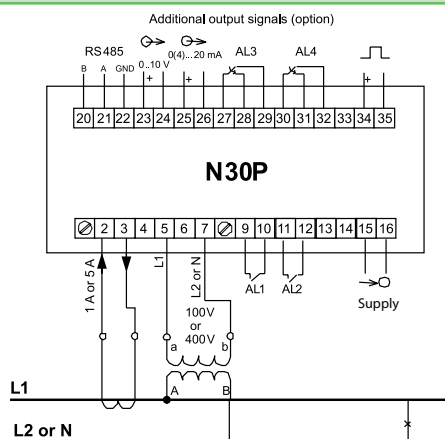

Fig. 2 Electrical connections of the N30P meter for indirect measurements.

## ORDERING

TABLE 1. ORDERING CODES:

	N30P -	X	X	XX	XX	X	X
<b>Supply:</b>							
85...253 V a.c./d.c.		1					
20...40 V a.c./d.c.		2					
<b>Additional outputs:</b>							
lack			0				
pulse output, RS-485, analog outputs			1				
pulse output, RS-485, analog outputs switched-over relay outputs			2				
<b>Unit:</b>							
unit code acc. to the table 2				XX			
<b>Version:</b>							
standard						00	
custom-made*						XX	
<b>Language:</b>							
Polish							P
English							E
other*							X
<b>Acceptance tests:</b>							
without extra requirements							0
with an extra quality inspection certificate							1
acc. to customer's request*							X

**Order example:** The code **N30P - 1 0 01 00 E 0** means: programmable N30P panel digital meter, supply: 85...253 V AC/DC, lack of additional outputs, unit "V" acc. to codes table 2, standard execution, English language, without extra requirements.

TABLE 2. CODES OF HIGHLIGHTED UNIT:

Code	Unit	Code	Unit	Code	Unit
00	lack of unit	20	kVAh	40	szt.
01	V	21	MVAh	41	imp
02	A	22	Hz	42	rps
03	mV	23	kHz	43	m/s
04	kV	24	Ω	44	l/s
05	mA	25	kΩ	45	obr/min
06	kA	26	°C	46	rpm
07	W	27	°F	47	mm/min
08	kW	28	K	48	m/min
09	MW	29	%	49	l/min
10	var	30	%RH	50	m <sup>3</sup> /min
11	kvar	31	pH	51	obr/h
12	Mvar	32	kg	52	m/h
13	VA	33	bar	53	km/h
14	kVA	34	m	54	m <sup>3</sup> /h
15	MVA	35	l	55	kg/h
16	kWh	36	s	56	l/h
17	MWh	37	h	XX	on order*
18	kvarh	38	m <sup>3</sup>		
19	Mvarh	39	obr		

\* - after agreeing with the manufacturer