



Technical Data Sheet

EPSILON CAM SPRING RETURN SERIES



EPSILON CAM SPRING RETURN SERIES provide contacts that are held closed only when the switch is turned against the mechanism spring. The mechanism returning the contacts to their original state upon release of the actuator. This type of switches are known as "Momentary switches".

- Epsilon Spring Return 16 A
- Epsilon Spring Return 25 A

Special Features

- Compact Design
- 60 & 90 Degree Angle of Throw
- Flag Type Knob Handle
- Spring Loaded Mechanism
- Standard Mounting Plate
- IP 20 (16A)

Application

- Industrial Panel
- Generator Controls
- Motor Controls
- Mains Switching
- Coolant Pumps

Spring return switches are used to energise contactors for controlling motor operation. It offers unique alternative to multiple " Push Botton Stations " when one switch controls instead of many pus h bottoms.

A focused range of Cam Spring Return Series switches cover most of applications with different contact designs , contact materials and terminal allow their use as control switches as well as in electronic circuitry and in aggressive environment according to IEC/EN 60947-1,3 & 5

Dimensions Details

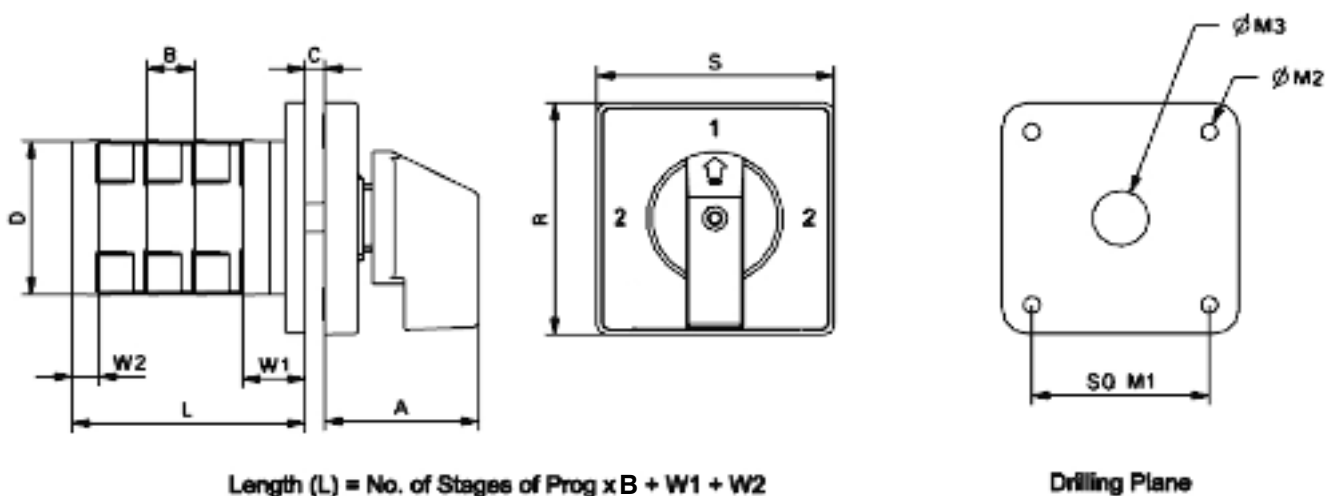

Type	A	B	C _(Max.)	D	M1	M2	M3	R	S	W1	W2
Epsilon 16A	29	9.5	4	43	36	4	7	60	48	19	5
Epsilon 25A	34	14.3	4	53	48	4	12	64	64	24	6.2

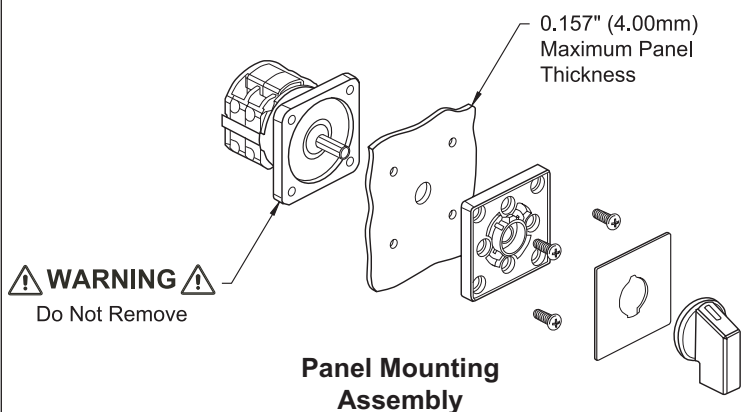

AC Duty Ratings

Category	Typical AC Application
AC-1	Non-Inductive or slightly inductive loads, Resistance furnaces
AC-3	Squirrel-cage motors: starting switching off motors during running
AC-15	Control of AC electromagnetic loads
AC-21-A	Switching of resistive loads, including moderate overloads (frequent switching)
AC-23-A	Switching of motor loads or other highly inductive loads (frequent switching)

ISOLATER

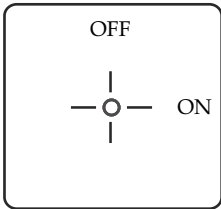

ON-OFF Spring Return Switches		Current Rating	
Description		16A	25A
ON OFF SPRING RETURN 90D 1P OFF		*	*
ON OFF SPRING RETURN 90D 2P OFF		*	*
ON OFF SPRING RETURN 90D 3P OFF		*	*
ON OFF SPRING RETURN 90D 4P OFF		*	*

Changeover switch

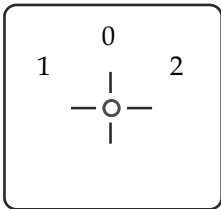

DOUBLE THROW with OFF		Current Rating	
Description		16A	25A
DOUBLE SPRING RETURN 60D 1P 2W with OFF		*	*
DOUBLE SPRING RETURN 60D 2P 2W with OFF		*	*
DOUBLE SPRING RETURN 60D 3P 2W with OFF		*	*

Changeover Without off

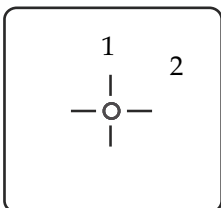

Spring Return Switches without OFF		Current Rating	
Description		16A	25A
SPRING RETURN 60D 1P 2W W/OFF		*	*
SPRING RETURN 60D 2P 2W W/OFF		*	*
SPRING RETURN 60D 3P 2W W/OFF		*	*

Technical Specifications

Conformance to standards : European : IEC 60947-1 IEC 60947-3 IEC 60947-5 Indian : IS 13947-1/3/5		Operating Conditions : Frequency : 50/60 Hz Operating Temp. : -25°C to 60 °C Over voltage category : III Storage : -40°C to 80°C Max. Altitude : 2000 m IP : 50 Front		Switch Life : Mechanical Life : 1 Lac operations @ 300 Cycles/hr Electrical Life : 10,000 operations @ 100% Rated duty at 120 cycles/hr Contacts : Double break type AgNi Double break type AgCdO	
Parameter		Unit	16A	25A	
Rated operational voltage (Ue)		V	690	690	
Rated Insulation voltage (Ui)		V	690	690	
Rated operational current (Ie)		A	16	25	
Conventional free air thermal current (Ith)		A	20	32	
Rated short time withstand current (Icw)		(1s- Current) A	192*	300	
Rated Impulse withstand voltage (Uimp)		KV	4	6	
Rated Fuse short circuit current		KA	5	10	
Fuse size (Type gG / gM)		A	16	25	
AC23A 3phase		220-240V	KW	3	4.7
		380-440V	KW	5.5	7.5
		500V	KW	5.5	11
		660-690V	KW	5.5	11
AC23A 1phase		110V	KW	0.55	1.5
		220-240V	KW	1.5	3
		380-440V	KW	2.2	5.5
AC3 3phase		220-240V	KW	3	4.7
		380-440V	KW	5.5	7.5
		500V	KW	5.5	11
		600-690V	KW	5.5	11
AC3 1phase		110V	KW	0.55	1.5
		220-240V	KW	1.5	3
		380-440V	KW	2.5	5.5
AC21A/AC1			A	16	25
AC15		220-240V	A	5	8
		380-440V	A	4	5
Terminal cross -section					
Single / Multiple		Min	mm2	1.5	2.5
		Max	mm2	4	4
Fine strand with sleeve		Min	mm2	1	1.5
		Max	mm2	2.5	4
Terminal screw			Metric	M3	M4
Terminal tightening torque			Nm	0.8	1.2

* Rated short time withstand current (0.5s- current)

Ordering information

Product Code	CSRX-	X	X	X	XX	X	X	X	X	0	OST
	CSR1 : ON-OFF (16A)										
	CSR2 : DOUBLE THROW (16A)										
	CSR3 : SR WITHOUT OFF (16A)										
	CSR5 : ON-OFF (25A)										
	CSR6 : DOUBLE THROW (25A)										
	CSR7 : SR WITHOUT OFF (25A)										
Ampere code for CSRX	16A	A									
	25A	B									
Type for CSRX	ON-OFF spring return			1							
	Double throw with spring return			2							
	Spring return without OFF			3							
Poles for CSRX	1 Pole			1							
	2 Poles			2							
	3 Poles			3							
	4 Poles			4							
No of ways for CSRX	No ways				XX						
	2 Ways				02						
	4 Ways				04						
OFF for CSRX	Without OFF					w					
	With OFF					O					
Angle for CSRX	30 Degree						3				
	45 Degree						4				
	60 Degree						6				
	90 Degree						9				
Knob shape for CRF1	Flang Shape							F			
Front Plate colour for CRF1	Silver sheet & Black knob								A		
	Yellow sheet & Red knob								B		
Reserved										0	OST



Sifam Tinsley Instrumentation Ltd
 1 Warner Drive, Springwood Industrial Estate,
 Braintree, Essex CM7 2YW
 Contact No. : +44 (0) 1376 335271
[Email: sales@sifamtinsley.com](mailto:sales@sifamtinsley.com)
www.sifamtinsley.co.uk